

MVR-300™ VRF Refrigerant Leak Detector

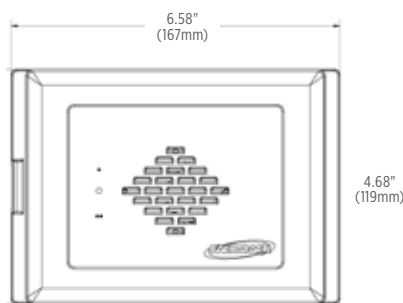

For VRF Systems in Occupied Spaces



FRONT

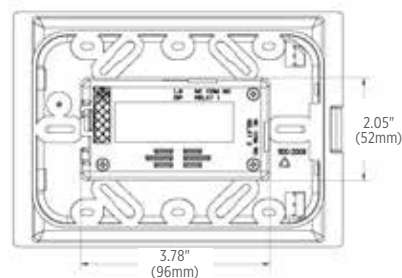

BACK

DESCRIPTION

The MSA Bacharach MVR-300 gas detector is specifically designed to provide continuous monitoring for refrigerants associated with high-efficiency, high volume refrigerant cooling and heating systems, such as VRF / VRV (Variable Refrigerant Flow / Variable Refrigerant Volume) systems. Typical applications include hotels, dormitories, hospitals, office buildings and apartment buildings.

The MVR-300 audible and visual alarms alert occupants and simultaneously communicate to Building Management Systems / Building Automation Systems (BMS / BAS). Two on-board relays can be used to close valves, activate alarm devices and exhaust fans or initiate emergency calls to building management.

The on-board Modbus RTU interface provides real-time information about refrigerant concentrations, status and settings. It also enables custom configuration of the MVR-300 to any application specific requirements using multiple Modbus registers. The MVR-300 is designed for easy installation and simple maintenance.

The MVR-300 is compatible with the MSA Bacharach MVR-SC Controller.

Features

Benefits

Fits in standard electrical boxes	Easy to install
Low profile / Flush mount	Aesthetically non-intrusive appearance
Two relays and Modbus Communications	Notify building management & initiate counter measures
Alarm options including: LED, buzzer, two levels, configurable delay and fail-safe	Alert occupants and remotely inform building management of alarm location for rapid response as required
Refrigerant specific sensor	Enhances safety ¹ and minimizes refrigerant loss
Self diagnostics and simple field calibration	Easy to maintain
Unique plug-in field replaceable pre-calibrated sensor	Low cost of ownership

Important Note: Large refrigerant leaks into occupied spaces can reach concentrations that pose a suffocation risk to the occupants. The MVR-300 is not designed to be used as the sole safety device for this risk. Safety of the occupants also must take a system designed approach that includes things such as ventilation, detection, early warning, mitigation and design redundancy.

Refrigerant	Part Number	Low Alarm*	High Alarm*	Range
R-410A	6203-0001	500 ppm	2,000 ppm	2,500 ppm
	6203-0002	1,000 ppm	2,000 ppm	5,000 ppm
	6203-0003	2,000 ppm	4,000 ppm	10,000 ppm
R-32	6203-0041	500 ppm	2,000 ppm	2,500 ppm
	6203-0042	1,000 ppm	2,000 ppm	5,000 ppm
	6203-0043	2,000 ppm	4,000 ppm	10,000 ppm

*Factory default; can be changed through Modbus. Recommended 6 month testing / recalibration



MORE INFORMATION:

Scan the QR code to learn more about the MVR-300 and other MSA Bacharach products.

MVR-300™ VRF Refrigerant Leak Detector



Specifications	Description
Detectable Gases	R-410A, R-32
Measuring Ranges	2,500 ppm, 5,000 ppm, 10,000 ppm
Housing	Flush mount, white ABS, Fits in most 3-gang electrical boxes (not suitable for electrical Junction boxes)
Size (L × W × D, approx.)	6" × 4.1" × 1.75" (150 × 105 × 45 mm) including bezel
Protection	Indoor: IP40, NEMA 1
Weight (approx.)	8 oz (230 g)
Power	100 to 240 VAC, 50/60 Hz, 4 W max
Indicator	Tri-color LED: green, amber, red
Buzzer	80 dB at 12" (30 cm)
Relay	Two SPDT: low alarm and high alarm / fault, normal or fail-safe, configurable
Alarm Delay	0 to 15 minutes, configurable 0, 5, 10, 15
Wiring	Power: 3-core cable, 14 to 20 AWG (0.5 to 2.0 mm ²) Relay: 3-core cable, 18 to 20 AWG (0.5 to 1.0 mm ²) Modbus: 2-core twisted pair shielded cable 18 to 24 AWG
Modbus RTU	Baud Rate: 9,600 or 19,200, configurable
Environmental Conditions	Operating Temperature: 32 to 120 °F (0 to 50 °C) Storage Temperature: 5 to 100 °F (-20 to 40 °C) Humidity: 5 to 90% RH, non-condensing Pressure: 23.6 to 32.5 inch of Hg (800 to 1,100 hPa)
Elevation	0 to 6,560' (2,000 m) altitude
Sensor Life	2 year minimum life with recommended 6 month testing and / or recalibration
Approvals	CE, UL/SCA/IEC/EN 61010-1



THE MVR-SC CONTROLLER

The MSA Bacharach MVR-SC Refrigerant Leak Monitor provides centralized monitoring and alarming for multi-occupant applications utilizing the MVR-300™ VRF Refrigerant Leak Detector. The MVR-SC continuously monitors all connected gas detectors for alarm and fault conditions, and will provide alerts via the integrated color touchscreen display, integrated buzzer, and on-board relay outputs.

Note: This Bulletin contains only a general description of the products shown. While product uses and performance capabilities are generally described, the products shall not, under any circumstances, be used by untrained or unqualified individuals. The products shall not be used until the product instructions/user manual, which contains detailed information concerning the proper use and care of the products, including any warnings or cautions, have been thoroughly read and understood. Specifications are subject to change without prior notice. MSA is a registered trademark of MSA Technology, LLC in the US, Europe, and other Countries. For all other trademarks visit <https://us.msasafety.com/Trademarks>.

MSA operates in over 40 countries worldwide. To find an MSA office near you, please visit [MSAsafety.com/offices](https://us.msasafety.com/offices).